

## Blackmagic Pocket Cinema Camera 4K



The Blackmagic Pocket Cinema Camera 4K features 4/3 size sensor, 13 stops of dynamic range and dual native ISO up to 25,600 for HDR images and incredible low light performance. External controls give quick access to essential functions, while the large 5 inch touchscreen makes it easy to frame shots, focus accurately and change camera settings. Features include built in SD/UHS-II or CFast 2.0 recorders for RAW or ProRes recoding as well as a USB-C expansion port for recording externally to disks, plus MFT lens mount, built-in microphones, XLR input, full sized HDMI, 3D LUT support, Bluetooth and more.

### Camera Features

#### Effective Sensor Size

18.96mm x 10mm (Four Thirds)

#### Lens Mount

Active MFT mount.

#### Lens Control

Iris, focus and zoom on supported lenses.

#### Dynamic Range

13 Stops.

#### Shooting Resolutions

4096 x 2160 (4K DCI), 3840 x 2160 (Ultra HD), 1920 x 1080 (HD).

#### Frame Rates

Maximum sensor frame rate dependent on resolution and codec selected. Project frame rates of 23.98, 24, 25, 29.97, 30, 50, 59.94 and 60 fps supported.

Off-speed frame rates up to 60 fps in 4K DCI, 120 fps in HD windowed.

#### Focus

Focus button turns on peaking, auto focus available using compatible lenses.

#### Iris Control

Iris wheel and touchscreen slider for manual iris adjustment on electronically controllable lenses, iris button for instant auto iris settings on compatible lenses so no pixel is clipped in film mode. Scene average auto exposure in video mode.

#### Screen Dimensions

5" 1920 x 1080.

#### Screen Type

LCD capacitive touchscreen.

#### Metadata Support

Automatically populated lens data from electronic Micro Four Thirds lenses. Automatic recording of camera settings and slate data such as project, scene number, take and special notes.

#### Controls

Touchscreen menus on 5 inch screen. 1 x Power Switch, 1 x Record Button, 1 x Stills Button, 1 x Scroll Wheel with push integrated into handgrip, 1 x ISO Button, 1 x White Balance, 1 x Shutter Button, 3 x software configurable Fn buttons, 1 x High Frame Rate (HFR) Button, 1 x Zoom Button, 1 x Menu Button, 1 x Play Button, 1 x Focus Button and 1 x IRIS Button.

---

## Connections

### **Total Video Inputs**

None.

### **Total Video Outputs**

1 x HDMI Type A

### **Analog Audio Inputs**

1 x mini XLR analog switchable between mic with phantom power support and line level (up to +14dBu).  
1 x 3.5mm Stereo Input. Can also be used for Timecode input.

### **Analog Audio Outputs**

1 x 3.5mm headphone jack.

### **Computer Interface**

USB Type-C for external drive recording, software updates and media download.

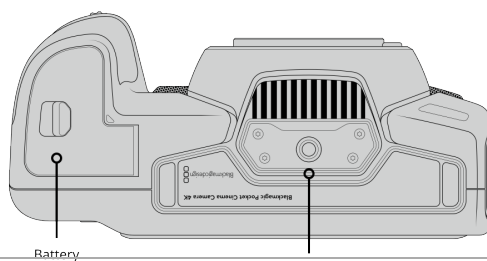
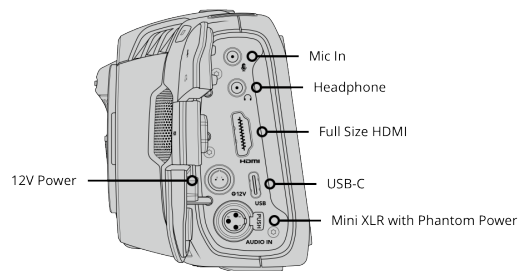
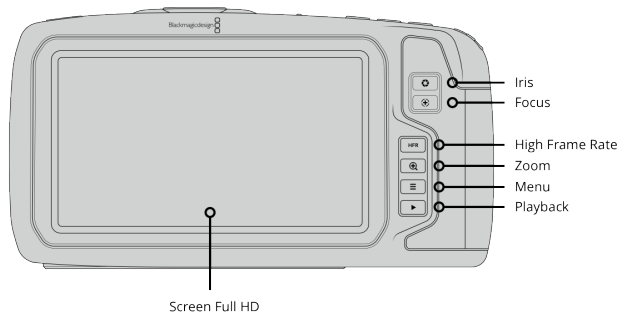
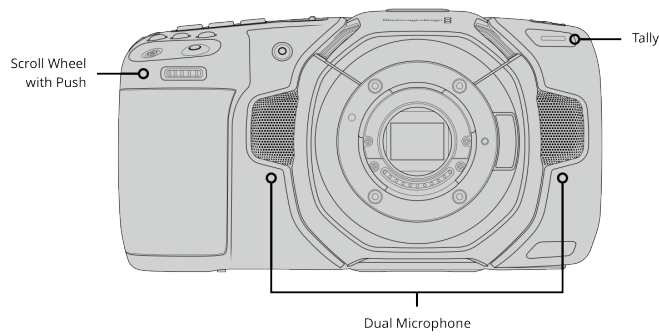
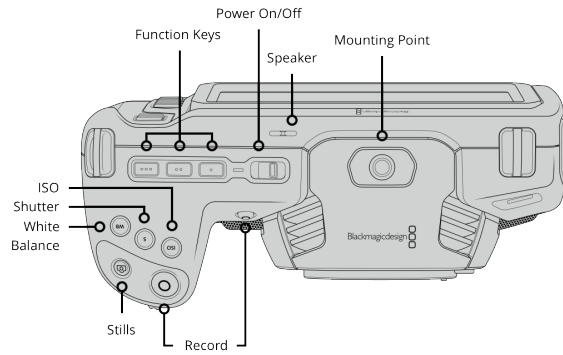

---

## Audio

### Microphone

Integrated stereo microphone.

### Built in Speaker

1 x mono speaker.

---

## Standards

### SD Video Standards

None.

### HD Video Standards

1080p23.98, 1080p24, 1080p25,  
1080p29.97, 1080p30, 1080p50,  
1080p59.94, 1080p60.

### Ultra HD Video Standards

2160p23.98, 2160p24, 2160p25,  
2160p29.97, 2160p30, 2160p50,  
2160p59.94, 2160p60.

### 4K DCI Standards

4KDCIp23.98, 4KDCIp24, 4KDCIp25,  
4KDCIp29.97, 4KDCIp30, 4KDCIp50,  
4KDCIp59.94, 4KDCIp60.

---

## Media

### Media

1 x CFast and 1 x SD USH-II card slot  
for CinemaDNG Raw and ProRes  
Recording. Actual supported codec  
and frame rates are media  
dependent.

### Media Format

Can format cards to ExFAT for  
Windows and Mac or HFS+ for Mac  
(file systems).

---

## Supported Codecs

### Codecs

CinemaDNG RAW, CinemaDNG RAW  
3:1, CinemaDNG RAW 4:1, ProRes 422  
HQ QuickTime, ProRes 422  
QuickTime, ProRes 422 LT QuickTime,  
ProRes 422 Proxy QuickTime.

---

## Storage Features

### Storage Type

1 x CFast 2.0.

1 x SD UHS-II card.

---

---

### Storage Rates

4096 x 2160  
CinemaDNG RAW - 270 MB/s  
CinemaDNG RAW 3:1 - 128 MB/s  
CinemaDNG RAW 4:1 - 96 MB/s  
3840 x 2160  
Apple ProRes 422 HQ - 110 MB/s  
Apple ProRes 422 - 73.6 MB/s  
Apple ProRes 422 LT - 51 MB/s  
Apple ProRes Proxy - 22.4 MB/s  
1920 x 1080  
Apple ProRes 422 HQ - 27.5 MB/s  
Apple ProRes 422 - 18.4 MB/s  
Apple ProRes 422 LT - 12.75 MB/s  
Apple ProRes Proxy - 5.6 MB/s  
Storage rates based on 30 frames per second.

### Recording Formats

Lossless CinemaDNG RAW, RAW 3:1 and RAW 4:1 with film dynamic range at 4096 x 2160, 3840 x 2160 and 1920 x 1080. Apple ProRes 4096 x 2160, 3840 x 2160 and 1920 x 1080 with either film, video and extended video dynamic range.

---

## Software

### Software Included

Pocket Cinema Camera 4K Operating System.

DaVinci Resolve Studio on SD Card.

Blackmagic Camera Setup.

---

## Operating Systems



macOS 10.12 Sierra,  
macOS 10.13 High Sierra or later.



Windows 8.1 or Windows 10.

---

## Power Requirements

### Power Supply

1 x External 12V power supply.

### Battery Type

Canon LP-E6.

### Power

12V-20V

### External Power Input

1 x 2-pin locking connector.

### Battery Life

Approximately 60 minutes.

---

## Accessories

### Optional Accessories

---

## Physical Specifications



---

## Environmental Specifications

### Operating Temperature

0° to 40°C (32° to 104°F)

### Storage Temperature

-20° to 45°C (-4° to 113°F)

### Relative Humidity

0% to 90% non-condensing

---

## What's Included

Blackmagic Pocket Cinema Camera 4K  
Lens turret dust cap.  
30W power supply with locking connector and international adapters.  
SD card with software and manual.  
Welcome card.  
DaVinci Resolve Studio with activation key.

---

## Warranty

### Product Warranty

12 Month Limited Manufacturer's Warranty.

---

All items on this website are copyright Blackmagic Design Pty. Ltd. 2018, all rights reserved.  
All trademarks are property of their respective owners. MSRP excludes sales taxes/duties and shipping costs.  
This website uses remarketing services to advertise on third party websites to previous visitors to our site.  
You can opt out at any time by changing cookie settings.

Blackmagic Design Authorized Reseller